

1.1 GHz Prescaler for TV Tuners

Technology: Bipolar

Features

- Extrem low current consumption (typ. 17 mA)
- Output harmonics strongly reduced
- Scaling factor: 256
- High input sensitivity
- ECL output stage
- Electrostatic protection according to MIL-STD. 883

Case: 6 pin single inline plastic

Absolute Maximum Ratings

Reference point pin 1, unless otherwise specified

Parameters	Symbol	Value	Unit
Supply voltage Pin 4	V_S	6	V
Input voltage range Pin 5, 6	V_i	0 ... V_S	V
Junction temperature	T_j	125	°C
Ambient temperature range	T_{amb}	-25 ... +85	°C
Storage temperature range	T_{stg}	-40 ... +125	°C

Thermal Resistance

Parameters	Symbol	Maximum	Unit
Junction ambient	R_{thJA}	100	K/W

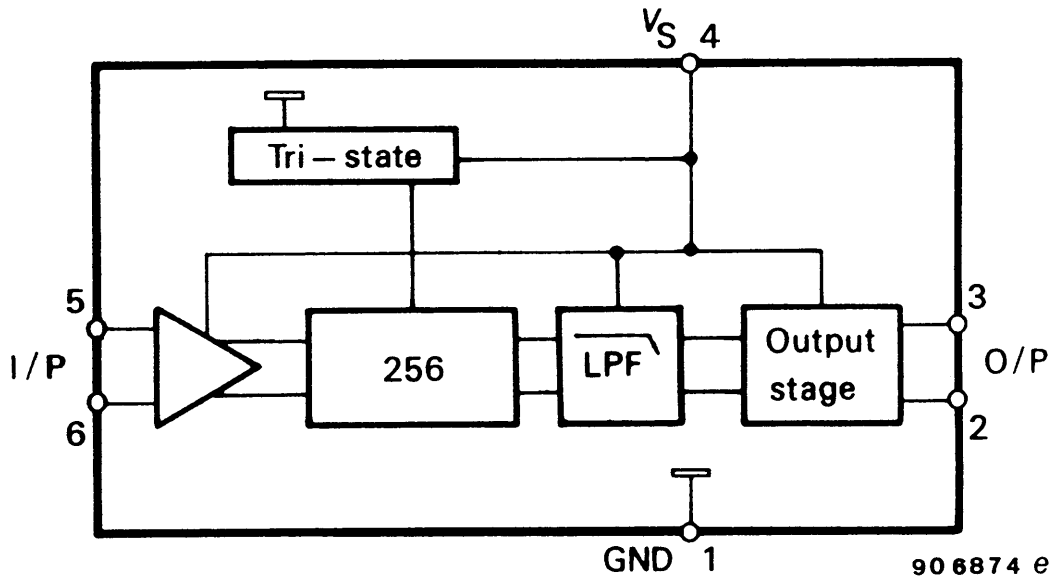

Figure 1 Block diagram

Pin Configuration

Pin	Function
1	Ground
2, 3	Output

Pin	Function
4	V_S
5,6	Input

Electrical Characteristics

$V_S = 4.5 \dots 5.5 \text{ V}$, $T_{\text{amb}} = 0 \dots 70 \text{ }^\circ\text{C}$, referred to test circuit unless otherwise specified

Parameters	Test Conditions / Pin	Symbol	Min	Typ	Max	Unit
Supply voltage range	Pin 4	V_S	4.5		5.5	V
Supply current	$V_S = 5 \text{ V}$ Pin 4	I_S		17	21	mA
Input sensitivity ¹⁾	$R_G = 50 \text{ } \Omega$					
	$f_i = 70 \dots 1000 \text{ MHz}$ Pin 5, 6	v_i			10	mV
	$f_i = 1000 \dots 1100 \text{ MHz}$ Pin 5, 6	v_i			15	mV
	$f_i = 1100 \dots 1200 \text{ MHz}$ Pin 5, 6	v_i			40	mV
Large signal compatibility	$R_G = 50 \text{ } \Omega$ Pin 5, 6	V_i	300			mV
Frequency range		$f_{i\text{min}}$			70	MHz
		$f_{i\text{max}}$	1200			MHz
Output stage						
Balanced ECL output	$f_i \leq 1000 \text{ MHz}$					
Voltage swing each output	$C_L = 13 \text{ pF}$, SF = 1:256 Pin 2, 3	V_O	0.6		1.2	V_{pp}
Output impedance	Pin 2, 3	Z_O		500		Ω

¹⁾ RMS-voltage calculated from the measured available power

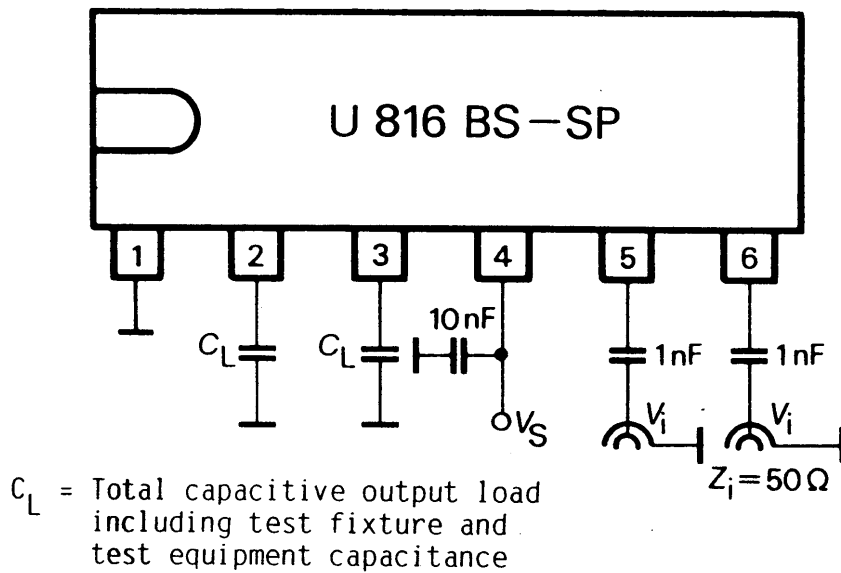

90 68 75 e

Figure 2 Test circuit

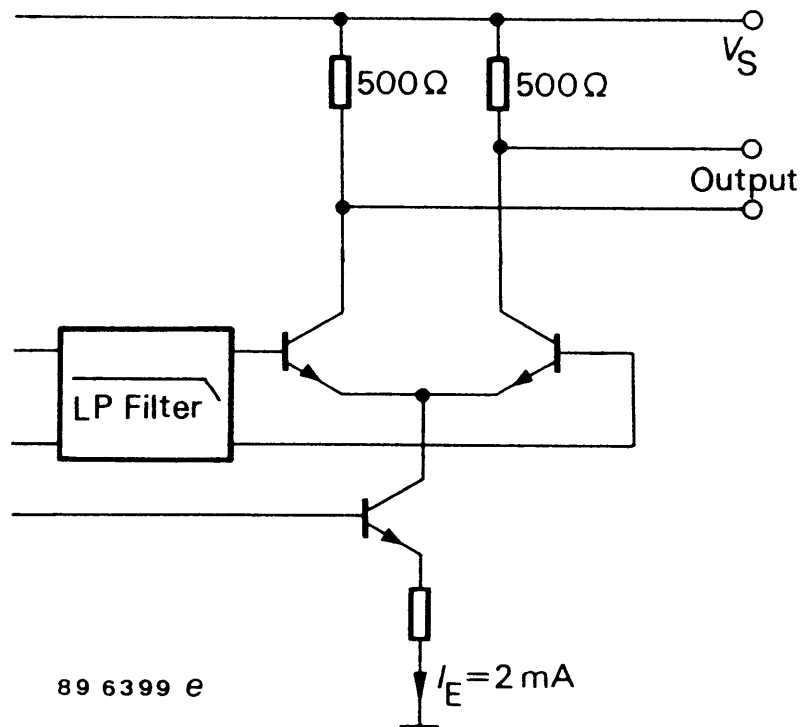

89 6399 e

Figure 3 Output circuit (ECL output)

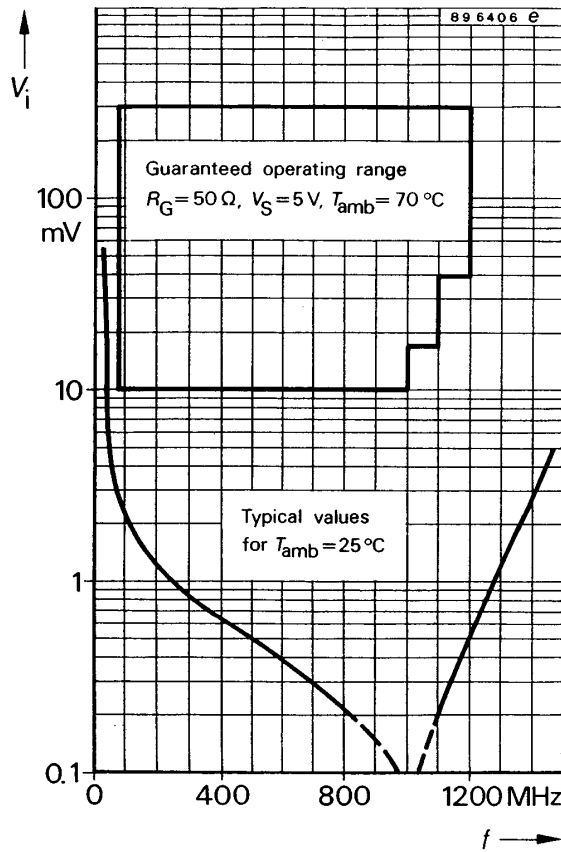
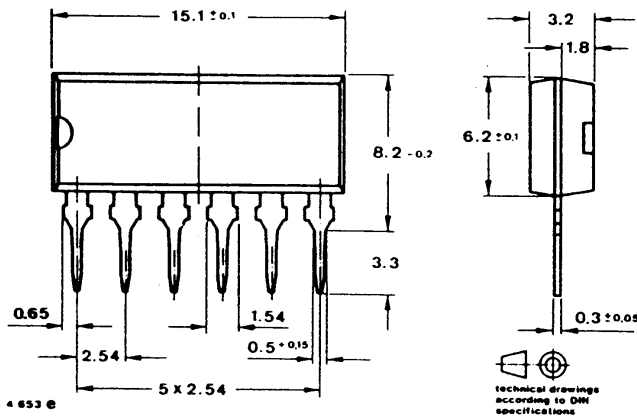

Figure 4 Input sensitivity

Dimensions in mm



Case
SIP 6

OZONE DEPLETING SUBSTANCES POLICY STATEMENT

It is the policy of **TEMIC TELEFUNKEN microelectronic GmbH** to

1. Meet all present and future national and international statutory requirements and
2. Regularly and continuously improve the performance of our products, processes, distribution and operating systems with respect to their impact on the health and safety of our employees and the public, as well as their impact on the environment.

Of particular concern is the control or elimination of releases into the atmosphere of those substances which are known as ozone depleting substances (ODSs).

The Montreal Protocol (1987) and its London Amendments (1990) will soon severely restrict the use of ODSs and forbid their use within the next ten years. Various national and international initiatives are pressing for an earlier ban on these substances.

TEMIC TELEFUNKEN microelectronic GmbH semiconductor division has been able to use its policy of continuous improvements to eliminate the use of any ODSs listed in the following documents.

1. Annex A, B and list of transitional substances of the Montreal Protocol and the London Amendments respectively
2. Class I and II ozone depleting substances in the Clean Air Act Amendments of 1990 by the Environmental Protection Agency (EPA) in the USA and
3. Council Decision 88/540/EEC and 91/690/EEC Annex A, B and C (transitional substances) respectively.

TEMIC can certify that our semiconductors are not manufactured with and do not contain ozone depleting substances.

We reserve the right to make changes without further notice to improve technical design.

Parameters can vary in different applications. All operating parameters must be validated for each customer application by customer. Should Buyer use TEMIC products for any unintended or unauthorized application, Buyer shall indemnify TEMIC against all claims, costs, damages, and expenses, arising out of, directly or indirectly, any claim of personal damage, injury or death associated with such unintended or unauthorized use.

TEMIC TELEFUNKEN microelectronic GmbH, P.O.B. 3535, D-74025 Heilbronn, Germany
Telephone: 49 (0)7131 67 2831, Fax Number: 49 (0)7131 67 2423